

The product using material and processing must conform to the "WL-PZ-001"HSF technical standard control requirements

RoHS

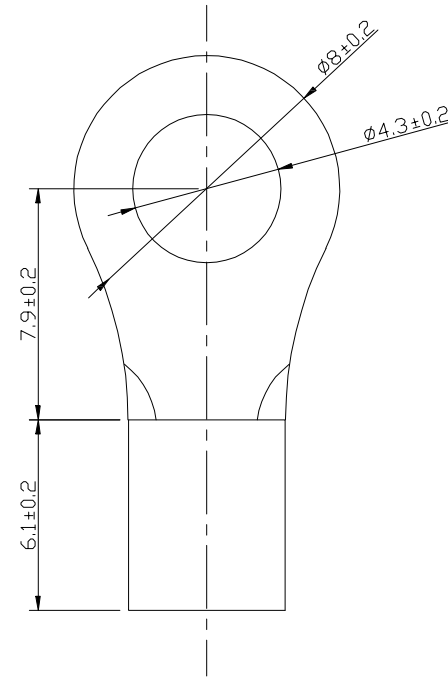
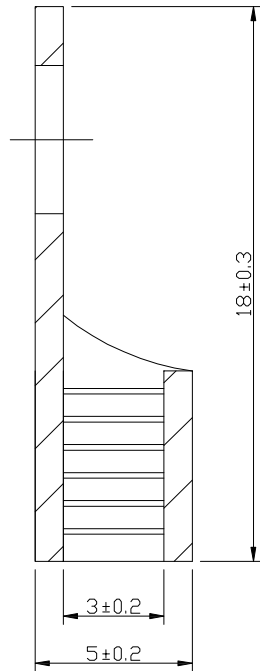

技术要求

- 1、材质：紫铜，厚度1mm
- 2、导线截面积：2.5~4mm²
- 3、最大电流：37A
- 4、表面处理：镀锡

REV.	REVISION RECORD	DATE		GENERAL TOLERANCES		SCALE: 1:1	NAME	DATE	PART.NO: RNB3.5-4	DWG.NO: ENDE05	 WanLian Technology Co., Ltd
A0	NEW RELEASE	22.10.28		LINEAR	ANGLES	APPROVED	Wang_jr	22.10.28			
			UNIT:mm	0.00±0.25	X'±3°	DESIGNER	Han_Gao	22.10.28	TITLE: 0形无绝缘端子 镀锡 RNB3.5-4		
			SIZE: A4	0.000±0.10	X'X' ±2°	DRAWN	LanXuan_Hou	22.10.28			REV: A0 SHEET: 1/1